



Typhoon HIL402.

Industry's first notebook size Hardware-in-the-Loop system.



Typhoon HIL

Ready, set, HIL.



Typhoon HIL

Completely new hardware.

HIL test and HIL certify your power electronics controllers with the industry leading hardware-in-the-loop system: HIL402.



Application

This compact, extremely powerful, 4-core HIL will give you all the tools you need to test your power electronics controllers in a wide range of applications: solar and wind power generation, battery storage, power quality and motor drives.

Highlights

- 20 ns PWM sampling time
- 0.5, 1 or 2 μ s real-time simulation step
- Built-in 32 channel oscilloscope
- Advanced machine solver

Unleash the HIL402

Engage the powerful HIL402 through the hallmark of Typhoon HIL user friendly design with industry leading software toolchain.

- Draw a converter power stage model in the Typhoon HIL schematic editor, press compile and run the model with a single click
- Verify the performance of your controller through a built-in deep memory mixed signal oscilloscope.
- Execute test scenarios directly from the control center.
- Automate the verification process with Python scripts.

Tried and tested software.

Industrial strength toolchain in an all-new hardware.

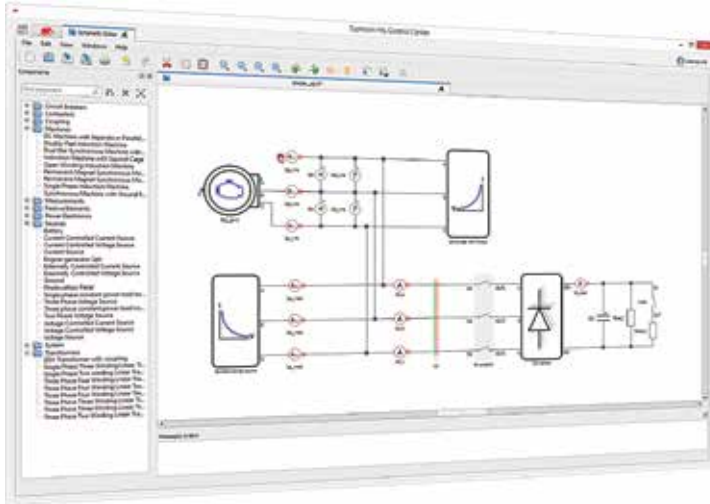

Comprehensive model library

Build your circuits from the elements in the extensive library comprising converters, switches, power sources and machines.

Compile and run your models on your HIL device with just one mouse click.

Built-in Scope and Capture

Typhoon HIL integrated oscilloscope and capture functions put **you** in control.

With 16 analog and 32 digital channels, 32 Mpts record length, and 1 MHz sample rate you will gain MRI (magnetic resonance imaging) vision into the inner workings of your control system even under the most extreme conditions, the conditions that are impossible or impractical to create in the laboratory.



Custom User Interface

A whole new level of user convenience.

Drag-and-drop gauges, meters, trace graphs, and monitors in order to customize the test environment according to your specific needs.

Even the most complex test environment is only a few mouse clicks away.

Signal processing unleashed.

Next-generation signal processing capabilities seamlessly integrated into the Typhoon HIL industry leading toolchain.

Groundbreaking new possibilities

Make use of Signal Processing Toolbox's comprehensive library of seamlessly integrated mathematical and logical functions.

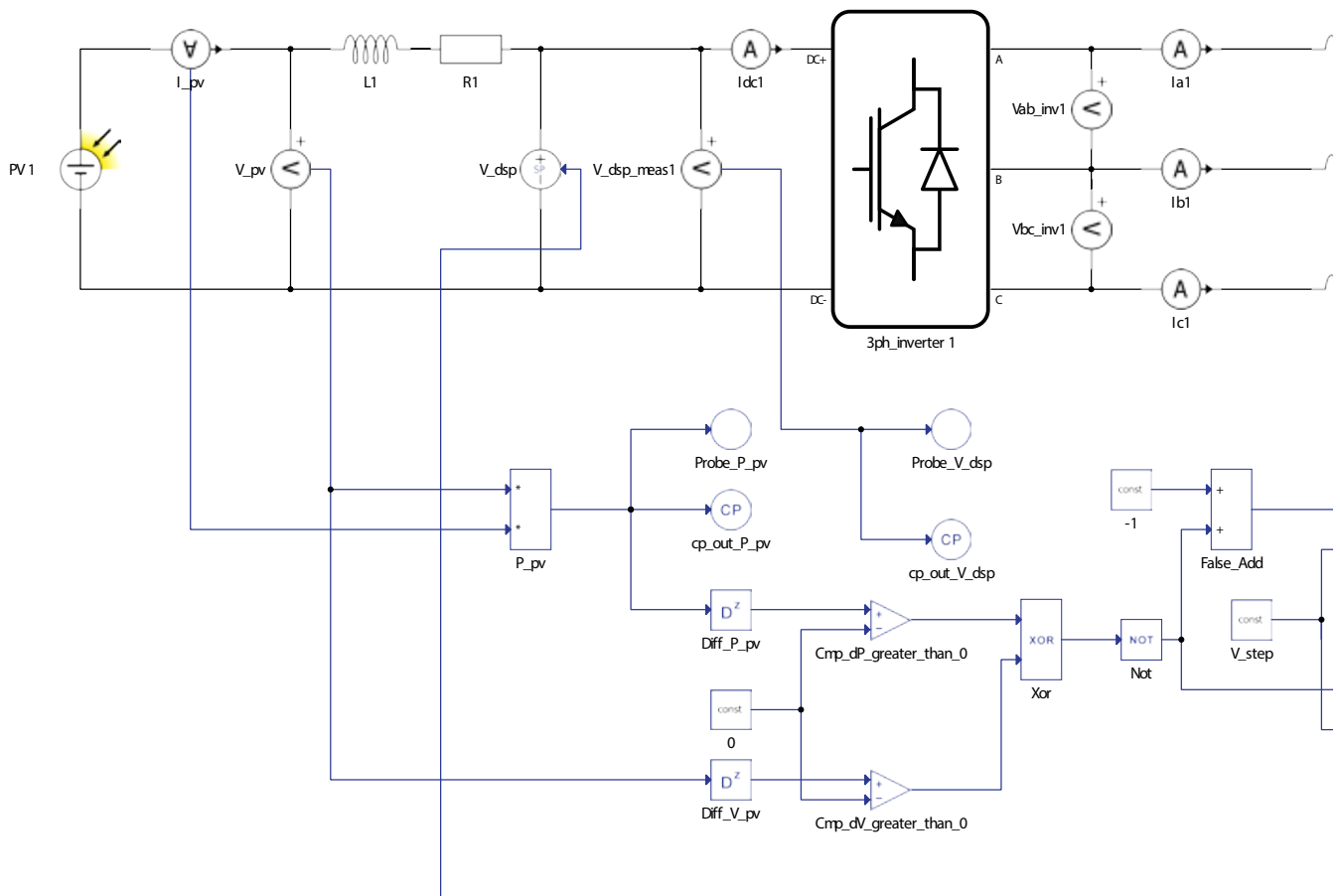

Seamless integration

Take full control of the numerical signals with the integrated Signal Processing Toolbox.

Control electrical sources and contactor devices, model mechanical subsystems or use machine speed and torque to trigger protection devices. It is all there.

Multi-rate execution

Simulate your numerical signals with multiple execution rates and improve the overall performance of your HIL system by maximizing the use of available resources. The built-in multi-rate interval overrun monitor closely supervises real-time execution and informs the user in case of potential performance issues.

As strong as an Elephant.

Signature software tool-chain fused with the unique hardware.



Typhoon HIL

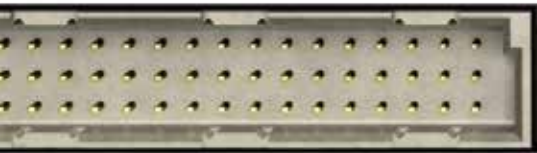

1

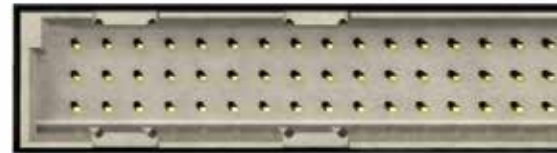

32

IO Robustness

We believe in a bulletproof HIL. That is why all the HIL IO pins are protected against:

- Short circuits
- Permanent ± 24 V overvoltages
- ESD discharge per IEC 61000-4-2

Beyond simulation

For most demanding HIL tests Typhoon HIL advanced numerical algorithms enable HIL tests that can run for weeks on end with our signature 1 μ s time step.

Top-end electrical components in the high quality aluminum enclosure bring unprecedented levels in electrical and mechanical reliability.

Our vertically integrated hardware, firmware and software solution guarantees an industry-leading user experience.

It is all about time.

1 μ s time step, 20 ns digital input sampling and ultra low latency make all the difference.

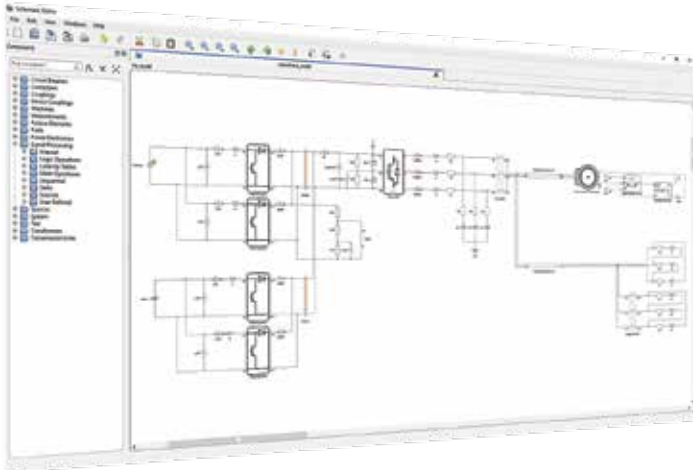

Ultra-fast real-time simulation

Leverage a small simulation time step and advanced numerical algorithms for an extremely wide dynamic range models.

Emulate fast switching dynamics with a simulation time step as low as 0.5 μ s, and have a full peace of mind that the part of your model with extremely long time constants will run beautifully as well.

Advanced numerical algorithms in Typhoon HIL handle the wide dynamic range models masterfully and run for weeks on end.

Digital inputs oversampling

Digital input signals are oversampled with a high resolution of 20 ns: as these are usually pulse width modulated gate drive signals, it is of crucial importance to capture the duty cycle as accurately as possible.

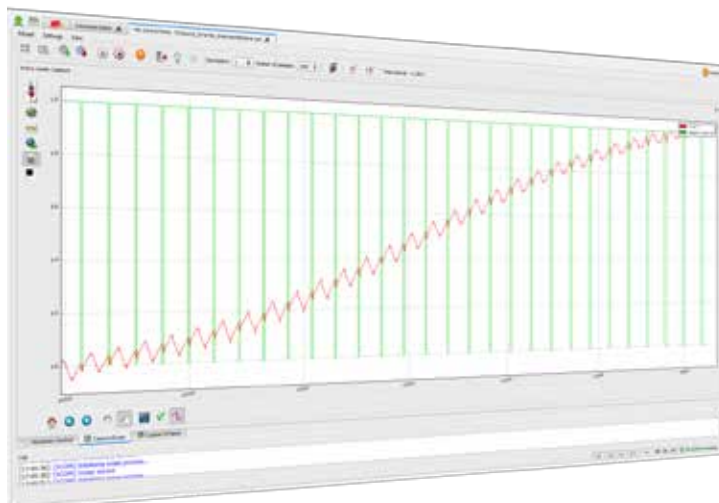
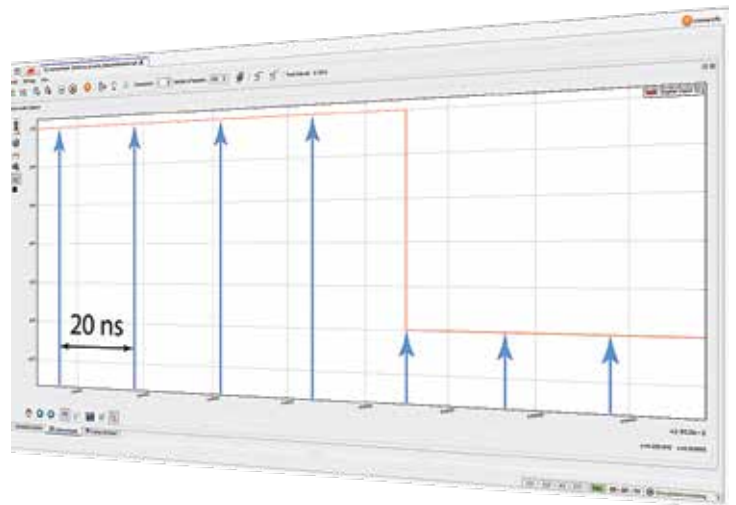

Ultra low latency

It can take as little as 20 ns to sample the digital output, calculate the model states and set the new values at HIL402 analog outputs.

This is what it takes to model converters with switching frequency as high as 200 kHz, and HIL402 does it masterfully.

Where emulation meets reality.

The next level in IO stage accuracy.

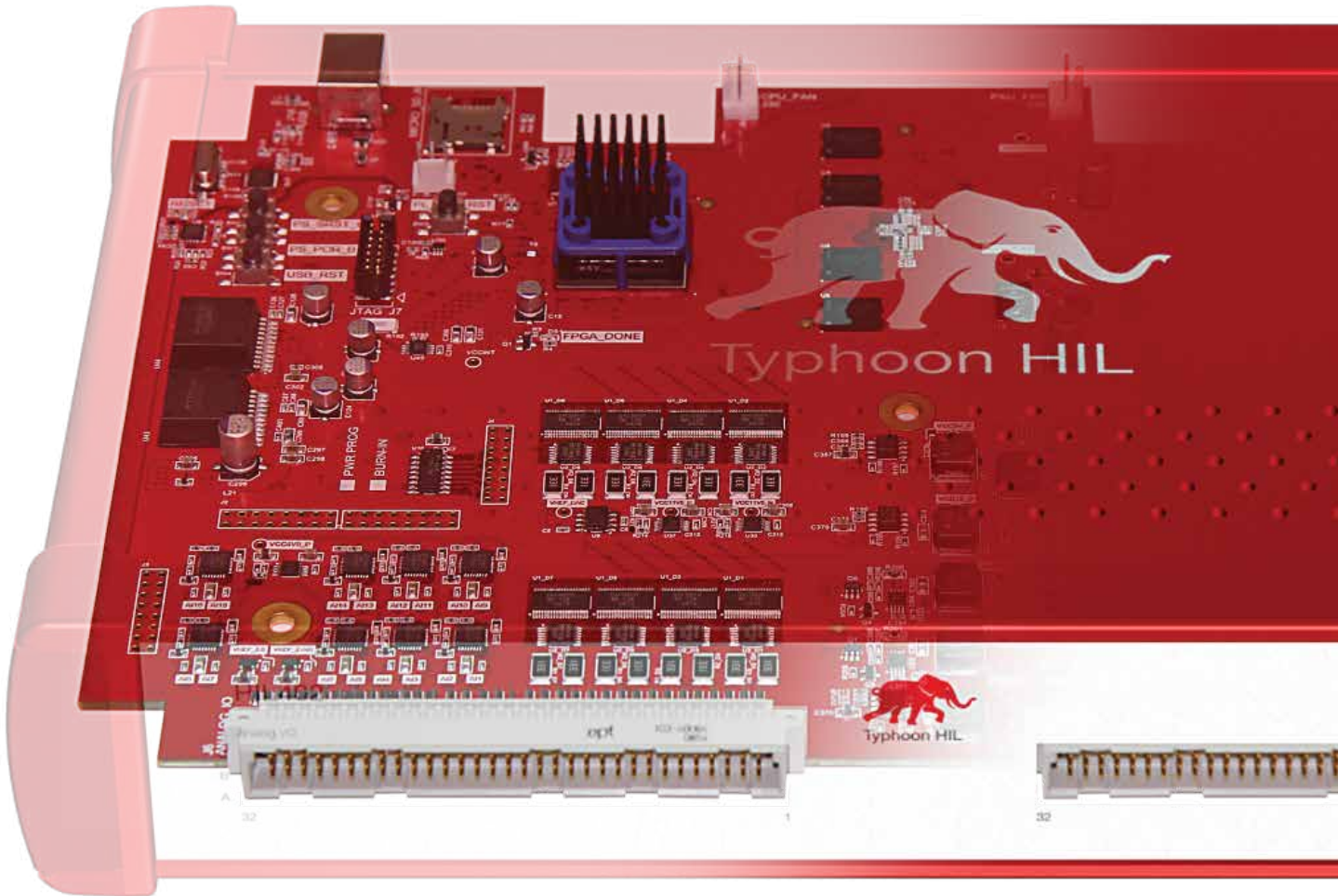

High accuracy analog IO

- simultaneous update on all outputs with 1 μ s update rate
- 16 inputs and 16 outputs
- 16 bit resolution
- ± 2 LSB (30 ppm) gain and offset error
- 10 ppm / $^{\circ}$ C temperature drift

High speed digital IO with digital input oversampling

In order to capture the duty cycle of high switching frequency converters accurately, all the digital input signals are oversampled at the rate of 50 MHz. In this way PWM converters with switching frequency as high as 200 kHz can be accurately modeled with HIL402 devices.

- 20 ns IO update rate
- 32 digital inputs and 32 digital outputs

HIL402 in action.

Test and verify converter control code. The Typhoon HIL way.



Test away from lab

Renewable energy systems comprise power electronics converters that interface with the electrical grid. Exhaustively testing power electronics control system's performance in the laboratory is costly and suffers from inherently limited opportunities for test automation.

The HIL402 provides a safe, high-fidelity environment for automatic test and verification of converters' control systems.

Test what you never could in the lab

Typhoon HIL402 environment allows you unprecedented control of active and reactive power flow, current harmonics and grid voltage sources with arbitrary magnitude, frequency and phase in just a few mouse clicks.

Furthermore, you can easily emulate utility grid disturbances such as voltage sags, spikes, phase angle jumps, magnitude ramps, frequency changes, harmonic distortion, etc. Any test scenario you can imagine HIL402 will execute for you.

HIL402 technical details.

Processor	XC7Z030 Zync SoC	Up to 4 cores
Analog I/O	Channels	16 inputs / 16 outputs
	Resolution	16 bit
	Voltage range	± 10 V
	Sample rate	1 MSPS
	Protection	± 24 V tolerant, ESD protection
	Connector	DIN 41612, type C, 96 pin male connector
Digital I/O	Channels	32 inputs / 32 outputs
	Threshold voltages (DI)	$V_{IL(max)} = 1.5$ V; $V_{IH(min)} = 3.5$ V
	Threshold voltages (DO)	$V_{OL(max)} = 0.2$ V; $V_{OH(min)} = 4.8$ V
	Protection	± 24 V tolerant, ESD protection
	Connector	DIN 41612, type C, 96 pin male connector
Externally available power supply	± 5 V analog	up to 1 A, resettable protection
	± 12 V analog	up to 0.5 A, resettable protection
	+ 3.3 V digital	up to 1 A, resettable protection
	+ 5 V digital	up to 1 A, resettable protection
Connectivity	USB	2.0 high speed, B-type connector
Compatibility	HIL DSP interface	
	HIL uGrid DSP interface	
	HIL Breakout board	
	HIL dSpace interface board	
Power supply	External	100 - 250 VAC, ≥ 60 W

Flipped classroom.

Teaching the Typhoon HIL way.



Imagine the power engineering instruction in which the technology enables students to develop their engineering intuition by playing with power systems like they play with computer games.

Then, motivated by the deep intuitive understanding of the system operation, they come to class to learn why systems behave the way they behave.

Imagine no more. Make it real. The HIL402 makes large scale unsupervised hands on instruction in the field of power engineering and Smart Grid possible.



Typhoon HIL, Inc.
35 Medford St. Suite 305
Somerville, MA 02143
USA

Phone: +1-800-766-3181

Typhoon HIL GmbH
Technoparkstrasse 1
CH-8005 Zürich
Switzerland

Phone: +1-800-766-3181

Tajfun HIL d.o.o.
Bulevar Oslobođenja 69/V
21000 Novi Sad
Republic of Serbia

Sales: +381 21 3010 474
Tech support: +381 21 3010 476

www.typhoon-hil.com
e-mail: info@typhoon-hil.com



Typhoon HIL